

The MOTOMAN MH6-10 is a compact and powerful 6-axis robot with high performance in a variety of applications such as machine tending, material handling and processing, where versatility is required. Its slim and lightweight design enables it to be positioned close to the work-piece to improve part accessibility.

Controlled by
DX100



Key benefits

- Compact and powerful
- Ideal for a variety of applications, multi-purpose robot
- Wide working envelope

MOTOMAN MH6-10

General purpose and handling

 YASKAWA

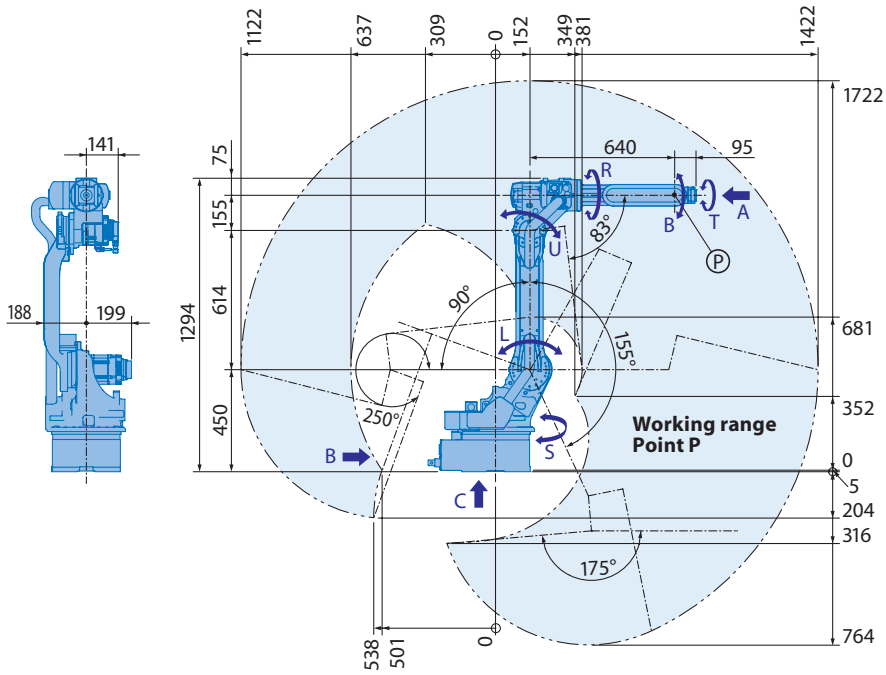

View A

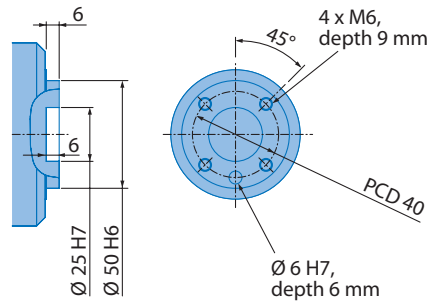

View B

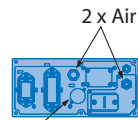

Internal user wiring connector
Media connector

View C

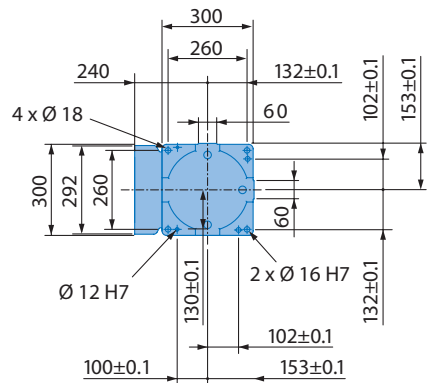

Mounting options: Floor, ceiling, wall

All dimensions in mm | Technical data may be subject to change without previous notice | Please request detailed drawings at robotics@yaskawa.eu.com – YR-MH00006-B30, E-04-2014, A-No. 150265

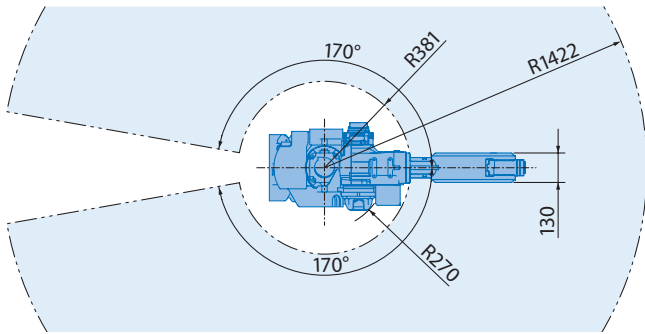

Allowable wrist load

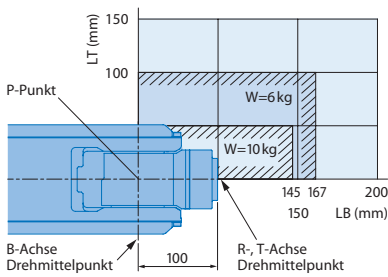

Allowable load on U-axis

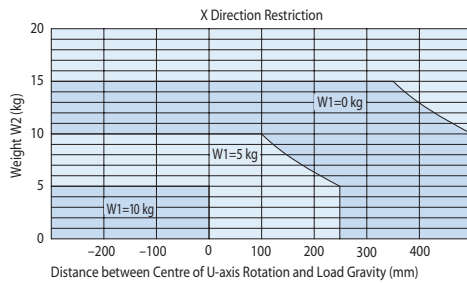

Specifications MH6-10

| Axes | Maximum motion range [°] | Maximum speed [°/sec.] | Allowable moment [Nm] | Allowable moment of inertia [kg · m ²] | Controlled axes | 6 |
|------|--------------------------|------------------------|-----------------------|--|-----------------------------|----------|
| S | ±170 | 140 | – | – | Max. payload [kg] | 10 |
| L | +155/–90 | 130 | – | – | Repeat. pos. accuracy [mm] | ±0.08 |
| U | +250/–175 | 135 | – | – | Max. working range [mm] | R = 1422 |
| R | ±180 | 270 | 12.2 | 0.24 | Temperature [°C] | 0 to +45 |
| B | +225/–45 | 270 | 14.2 | 0.21 | Humidity [%] | 20 – 80 |
| T | ±360 | 400 | 7.3 | 0.06 | Weight [kg] | 130 |
| | | | | | Power supply, average [KVA] | 1.5 |



YASKAWA Headquarters

YASKAWA Europe GmbH
Robotics Division
Yaskawastraße 1
D-85391 Allershausen
Tel. +49 (0) 81 66/90-0
Fax +49 (0) 81 66/90-103
robotics@yaskawa.eu.com
www.yaskawa.eu.com

YASKAWA academy and sales office Frankfurt

YASKAWA Europe GmbH
Robotics Division
Hauptstraße 185
D-65760 Eschborn
Tel. +49 (0) 6196/77725-0
Fax +49 (0) 6196/77725-39
robotics@yaskawa.eu.com
www.yaskawa.eu.com